

INTENTIONALLY LEFT BLANK

11.2 Appendix 2 – Figure 2 – Curved Take-Off Climb/Approach Surface

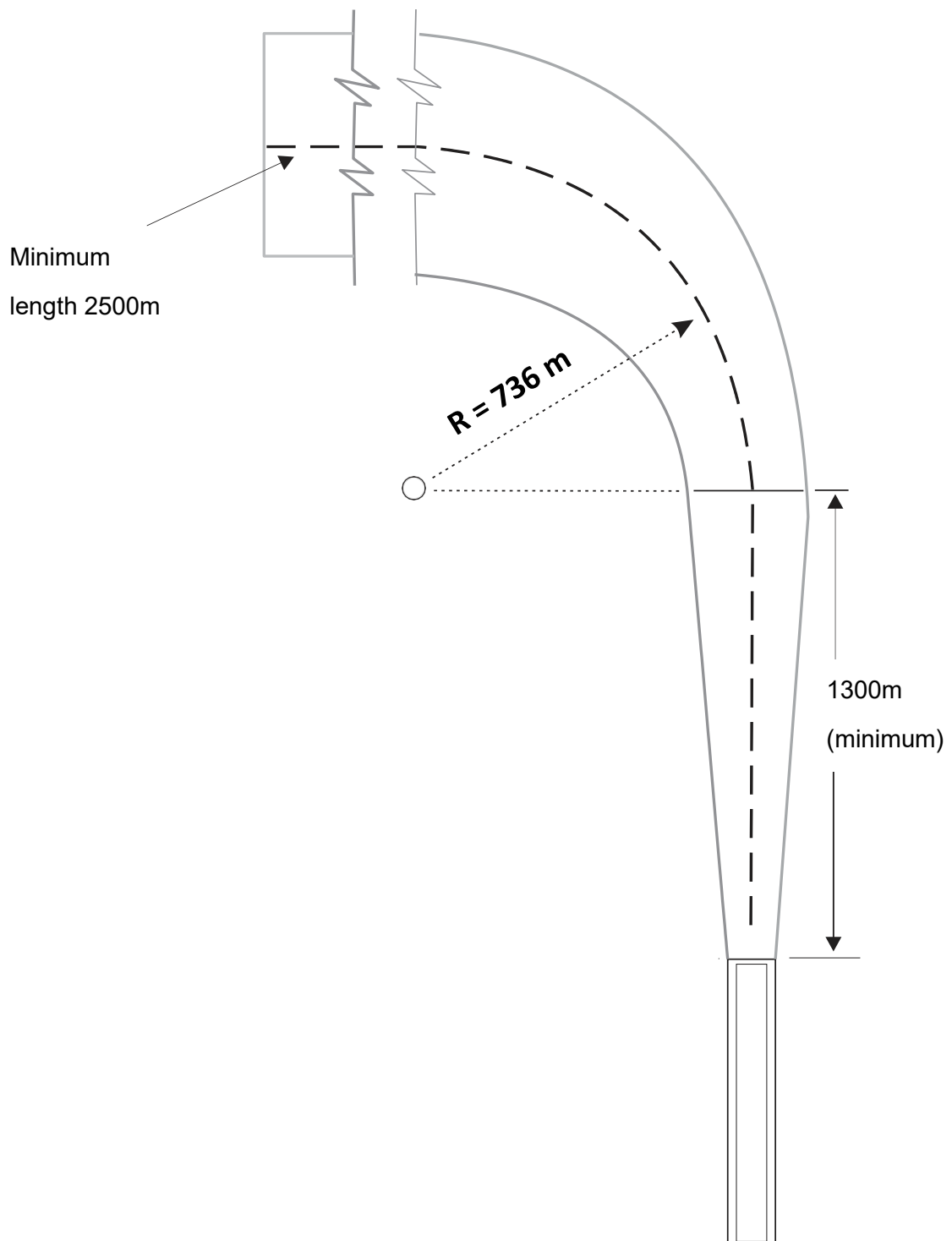



INTENTIONALLY LEFT BLANK